

ITEM NO.	PART NUMBER	DESCRIPTION	QTY.
1	2105-0001-0007	PM8 B.P. 4.1	1
2	2135-0006-0006	4.5" Pipe	1
3	Flir Navigator Top Plate	FLIR NAVIGATOR TOP PLATE	1

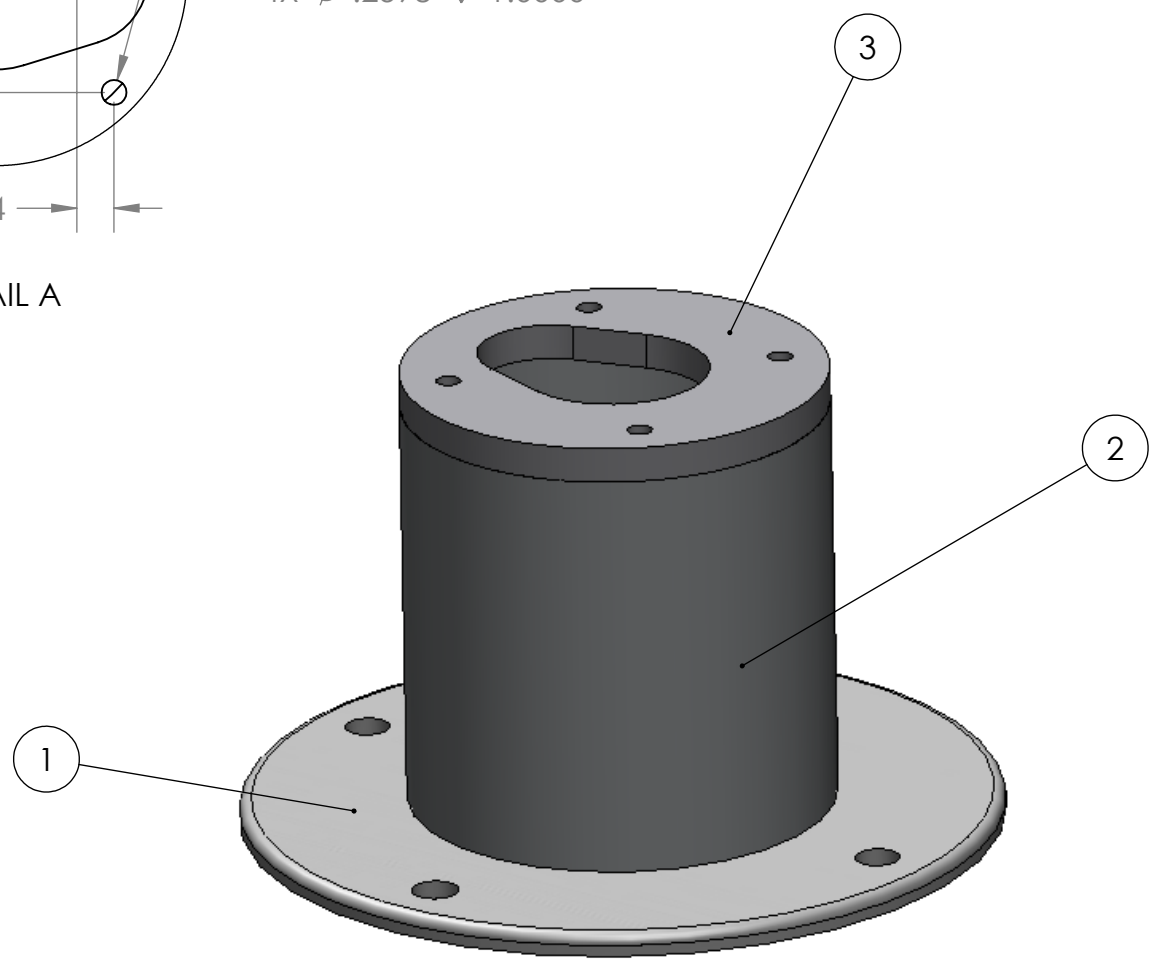

PROPRIETARY AND CONFIDENTIAL
 THE INFORMATION CONTAINED IN THIS DRAWING IS THE SOLE PROPERTY OF PYI, INC. ANY REPRODUCTION IN PART OR AS A WHOLE WITHOUT THE WRITTEN PERMISSION OF PYI, INC. IS PROHIBITED.

UNLESS OTHERWISE SPECIFIED:		NAME	DATE
DIMENSIONS ARE IN INCHES		DRAWN	JR 02.26.09
TOLERANCES:		CHECKED	
FRACTIONAL ±		ENG APPR.	
ANGULAR: MACH ± BEND ±		MFG APPR.	
TWO PLACE DECIMAL ±		Q.A.	
THREE PLACE DECIMAL ±		COMMENTS:	
INTERPRET GEOMETRIC TOLERANCING PER:			
MATERIAL			
FINISH			
NEXT ASSY	USED ON		
APPLICATION		DO NOT SCALE DRAWING	

PYI, INC.

TITLE:
5" MOUNT FOR FLIR NAVIGATOR

SIZE B	DWG. NO. PM-5FN-8	REV E
------------------	----------------------	-----------------

SCALE: 1:2 WEIGHT: SHEET 1 OF 1