

ITEM NO.	PART NUMBER	DESCRIPTION	Revision	QTY.
1	Die Cast PMA-5	DIE CAST 5" aft Itb version	A	1
2	PM Radar Plate 2.1	Power Mount Top Plate	N/C	1

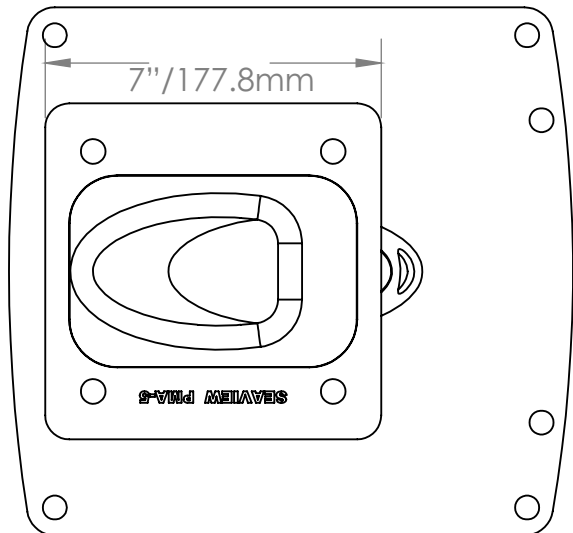
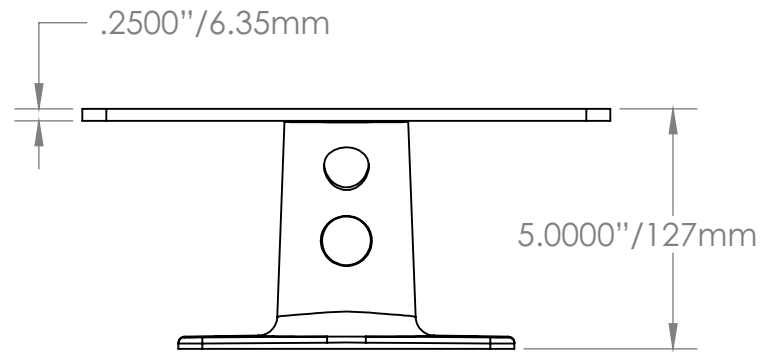
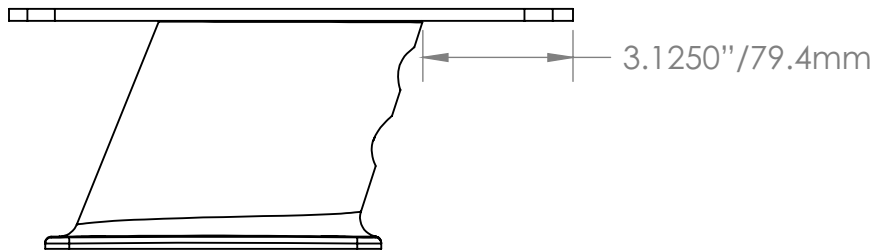
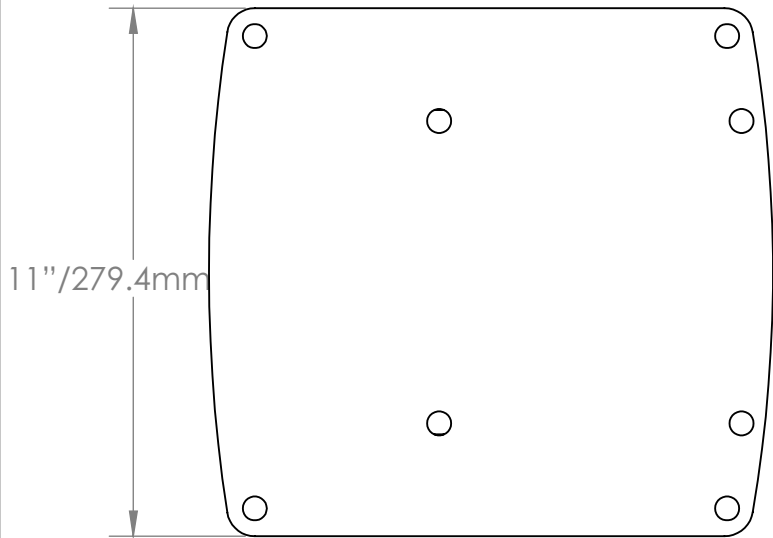

UNLESS OTHERWISE SPECIFIED:

DIMENSIONS ARE IN INCHES/mm
 TOLERANCES:
 FRACTIONAL ±
 ANGULAR: MACH ± BEND ±
 TWO PLACE DECIMAL ±
 THREE PLACE DECIMAL ±

INTERPRET GEOMETRIC
 TOLERANCING PER:

MATERIAL

FINISH

DO NOT SCALE DRAWING

NAME	DATE
JR	12/01/06

PYI, INC.

TITLE:
 DIE CAST PMA-5FJ-7L

PROPRIETARY AND CONFIDENTIAL
 THE INFORMATION CONTAINED IN THIS
 DRAWING IS THE SOLE PROPERTY OF
 PYI. NO REPRODUCTION IN PART OR
 AS A WHOLE WITHOUT THE WRITTEN
 PERMISSION OF PYI, INC

SIZE	DWG. NO.	REV
A	PMA-5FJ-7L (DC PMA-5)	N/C

SCALE: 1:4 WEIGHT: SHEET 1 OF 1